

**AUTO REVERSE  
DOCUMENT FEEDER  
(Machine Code: A548)**

# 1. SPECIFICATIONS

Original Size and Weight: Thick original mode (default mode)  
 Use this setting for normal paper types  
 Maximum A3, 11" x 17"  
 Minimum B6 (sideways), 5 1/2" x 8 1/2"  
 Weight 52 ~ 128 g/m<sup>2</sup> (14 ~ 34 lb)

Thin original mode  
 Maximum A3, 11" x 17"  
 Minimum B6, 5 1/2" x 8 1/2"  
 Weight 40 ~ 128 g/m<sup>2</sup> (11 ~ 34 lb)

Auto reverse mode  
 Maximum A3, 11" x 17"  
 Minimum B5, 5 1/2" x 8 1/2"  
 Weight 52 ~ 105 (14 ~ 27 lb)



Original Feed: Automatic feed - ADF mode  
 Manual feed one by one - SADDF mode  
 Auto Reverse Feed - ARDF mode

Original Table Capacity: 50 sheets at 80 g/m<sup>2</sup> (21 lb)

Original Placement: Face up, first sheet on top

Original Separation: Feed Roller and Friction Belt

Original Transport: One flat belt

Power Consumption: 45 W

Power Source: 24 V ± 10% from the copier, 1 

Dimensions (W x D x H): 610 x 507 x 130 mm (24.0" x 20.0" x 5.1")

Weight: Approximately 10.5 kg (23.2 lb)

---

## 2. COMPONENT LAYOUT

### 2.1 MECHANICAL COMPONENTS

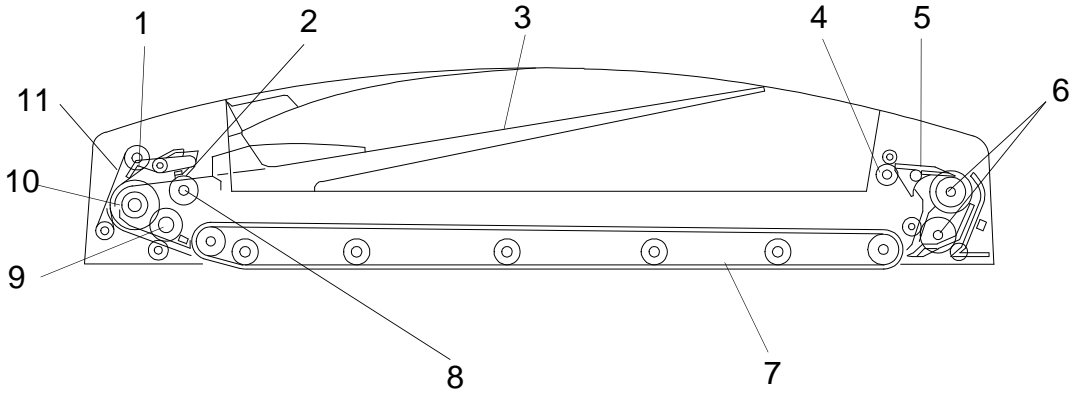

A548V502.wmf

- |                     |                    |
|---------------------|--------------------|
| 1. Original Stopper | 7. Transport Belt  |
| 2. Press Lever      | 8. Pick-up Rollers |
| 3. Original Table   | 9. Pull-out Roller |
| 4. Exit Rollers     | 10. Feed Roller    |
| 5. Inverter Pawls   | 11. Friction Belt  |
| 6. Inverter Rollers |                    |

## 2.2 ELECTRICAL COMPONENTS

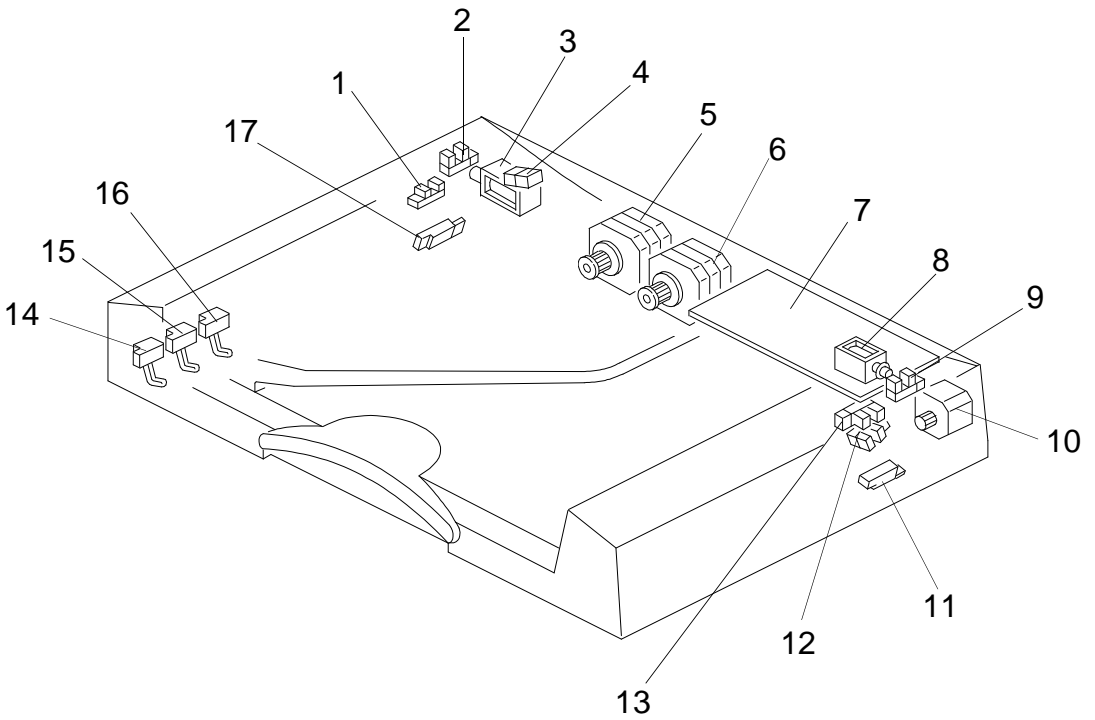

A548V503.wmf

- |                               |                               |
|-------------------------------|-------------------------------|
| 1. Original Set Sensor        | 10. Feed-out Motor            |
| 2. Feed-in Cover Open Sensor  | 11. Feed-out Sensor           |
| 3. Stopper Solenoid           | 12. APS Start Sensor          |
| 4. Indicator Panel Lamps      | 13. DF Position Sensor        |
| 5. Feed-in Motor              | 14. Original Width Sensor - 1 |
| 6. Belt Drive Motor           | 15. Original Width Sensor - 2 |
| 7. DF Main Board              | 16. Original Width Sensor - 3 |
| 8. Inverter Solenoid          | 17. Registration Sensor       |
| 9. Feed-out Cover Open Sensor |                               |

### 3. ELECTRICAL COMPONENT DESCRIPTION

Symbol	Name	Function	Index No.
<b>Motors</b>			
M1	Feed-in	Drives the feed-in system (pick-up, feed and pull-out rollers, separation belt)	5
M2	Belt Drive	Drives the transport belt	6
M3	Feed-out	Drives the feed-out and the inverter system	10
<b>Sensors</b>			
S1	Original Set	Detects whether originals have been placed on the original table	1
S2	Feed-in Cover Open	Informs whether the feed-in cover is open or not	2
S3	Feed-out Cover Open	Informs whether the feed-out cover is open or not	9
S4	Feed-out	Checks for original misfeeds and determines original stop timing when in auto-reverse mode	11
S5	APS Start	Informs the CPU that it is time to detect the original size (in platen mode)	12
S6	DF Position	Informs the CPU whether the DF is in the up or down position	13
S7	Original Width-1	Detects the width of the original	14
S8	Original Width-2	Detects the width of the original	15
S9	Original Width-3	Detects the width of the original	16
S10	Registration	Determines original stop timing and measures the length of the original	17
<b>Solenoids</b>			
SOL1	Stopper	Lifts the original stopper and lowers the feed-in lever to feed the set of originals to the feed roller	3
SOL2	Inverter	Energizes to invert the original when copying two-sided originals	8
<b>PCB</b>			
PCB1	DF Main Board	Controls all DF functions	7
<b>Indicators (Lamps)</b>			
L1	Ready	Informs the operator that the DF is in the down position.	4
L2	Auto	Informs the operator that the auto feed mode is available.	4

## 4. DETAILED DESCRIPTIONS

### 4.1 ORIGINAL PICK-UP MECHANISM

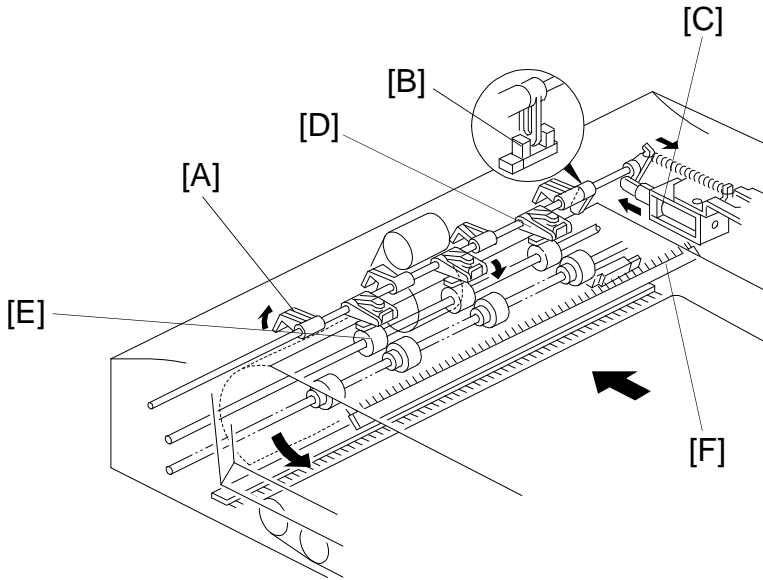

A548D514.wmf

When an original is placed on the table, the leading edge is stopped by the stopper [A], and the feeler activates the original set sensor [B]. The Insert Original indicator light goes out and the DF informs the copier's CPU that the originals have been set.

When the Print key is pressed, the stopper solenoid [C] activates to raise the stopper to allow the originals to be fed in, and to lower the press lever [D] to press the originals against the pick-up rollers [E].

An anti-static brush [F] is installed to eliminate static electricity caused during the original pick-up process.

## 4.2 SEPARATION AND PAPER FEED MECHANISM

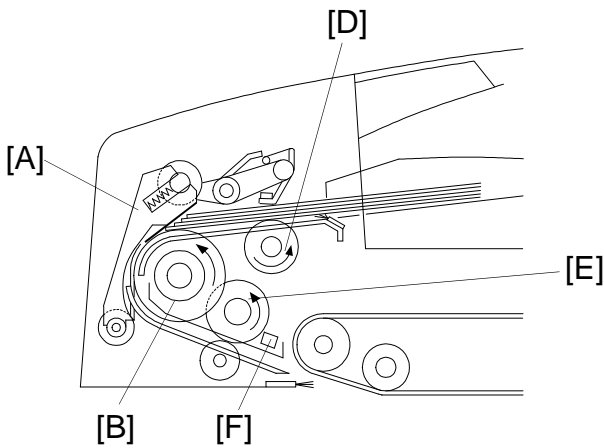

A548D515.wmf

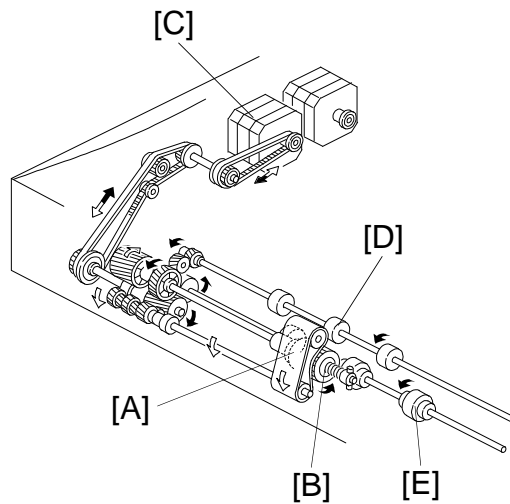

A548D516.wmf

Originals are separated using the friction belt [A] and the feed roller [B]. When the copier sends a signal to the DF to feed in the original, the feed-in motor [C] starts rotating (clockwise) to drive the pick-up [D], feed and pull-out [E] rollers. A one-way bearing stops the friction belt from rotating. Originals are separated and fed in one by one because the resistance of the stationary friction belt is greater than the friction between pages of the original.

When the registration sensor [F] detects the separated first original, the feed-in motor reverses (counter clockwise), and the drive is transmitted only to the pull-out rollers due to a one-way bearing. In this condition, the pull-out rollers are still rotating in the same direction, and they feed the original to the exposure glass. The motor turns off when the trailing edge of the 1st original has finished passing over the sensor.

To prepare the next original, the feed-in motor turns clockwise to separate the second original and the motor turns off when the registration sensor detects the second original. When it is time for the second original to be fed to the exposure glass, the feed-in motor turns counter clockwise.

### 4.3 FRICTION BELT DRIVE MECHANISM

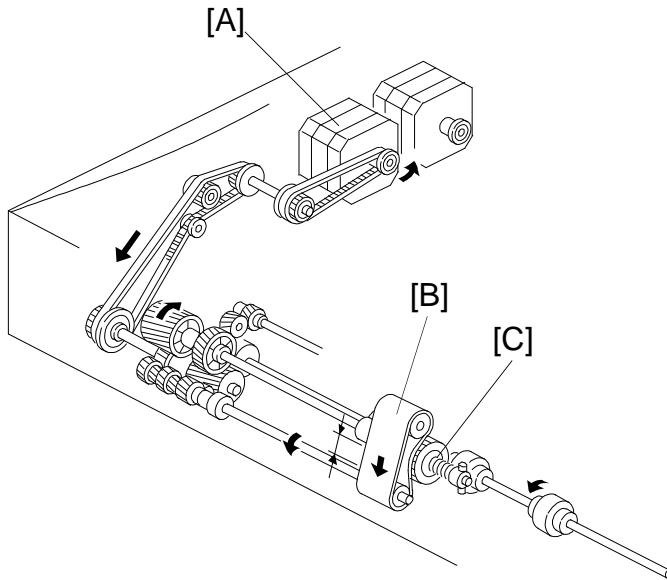

A548D517.wmf

The feed-in motor [A] drives the friction belt [B] through timing belts and gears. The one-way bearing allows the belt to rotate in the direction shown only when the feed-in motor is rotating counterclockwise. (The feed-in motor rotates counterclockwise when the original is passing over the registration sensor, and only the pull-out rollers are rotating to feed the paper to the exposure glass.)

As a result of this operation, the part of the friction belt that contacts the feed roller [C] or the original changes. This prevents multiple feeding or causing originals to become dirty.

The reverse movement of the friction belt will not affect the next original because the pressure of the press lever holds the originals in place.



## 4.4 ORIGINAL SIZE DETECTION

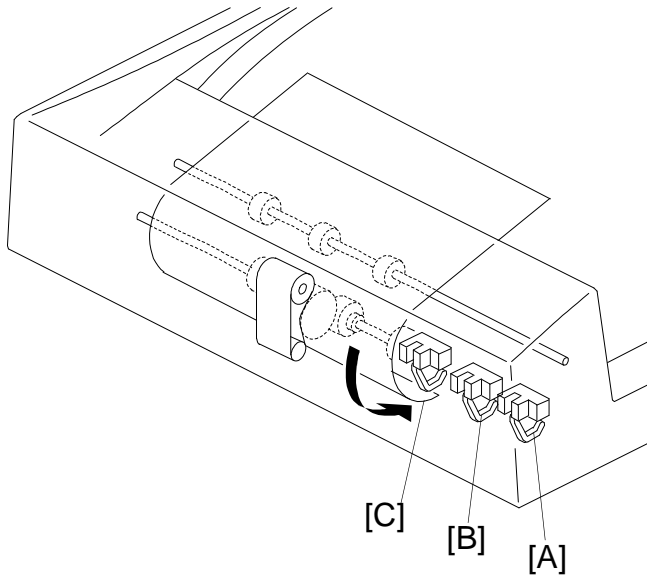

A548D518.wmf

The DF detects original width using three original width sensors-1 [A], -2 [B] and -3 [C]. It also detects the original length using the registration sensor.

The DF CPU counts the feed-in motor's drive pulses during the on timing of the registration sensor. Based on this pulse count, the CPU determines the original length.

The machine detects the original size by the total combination of all four sensors.

### 4.5 PAPER TRANSPORT MECHANISM

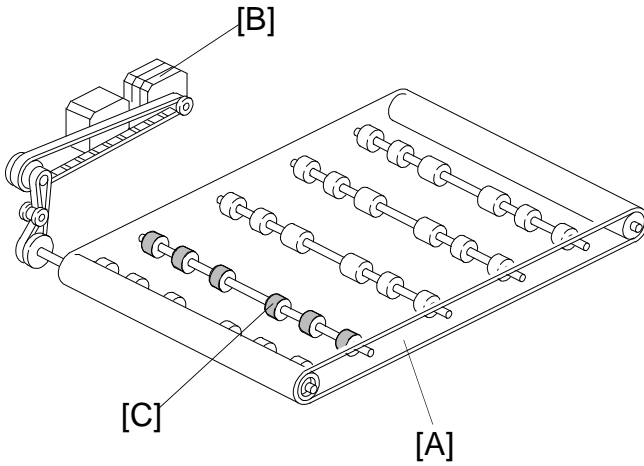

A548D519.wmf

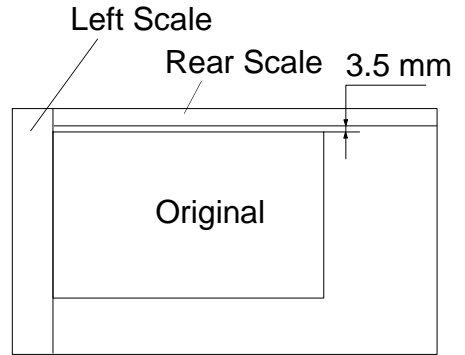

A548D520.wmf

The transport belt [A] is driven by an independent motor called the belt drive motor [B] (a dc stepper motor). The belt drive motor starts rotating soon after the copier sends an original feed-in signal.

Inside the transport belt are four pressure roller shafts, which achieve the proper amount of pressure between the belt and the original. The pressure roller shaft [C] closest to the left original scale is made of rubber for the stronger pressure that is required when in the thick original mode (this is the mode used for normal paper). The other rollers are sponge rollers.

Since the copier's original alignment position is at the left rear corner (not in the center), the originals fed from the DF must also be at this position. But if the original was to be fed along the rear scale, unnecessary original skew, jam or wrinkling may occur.

To prevent such problems, the original transfer position is set to 3.5 mm away from the rear scale as shown. The correction for this 3.5 mm gap is compensated for by the position of the lens unit. (Also see "Horizontal Lens Positioning" in the Optics section of the manual for the copier main body.)

## 4.6 THICK/THIN ORIGINAL MODES

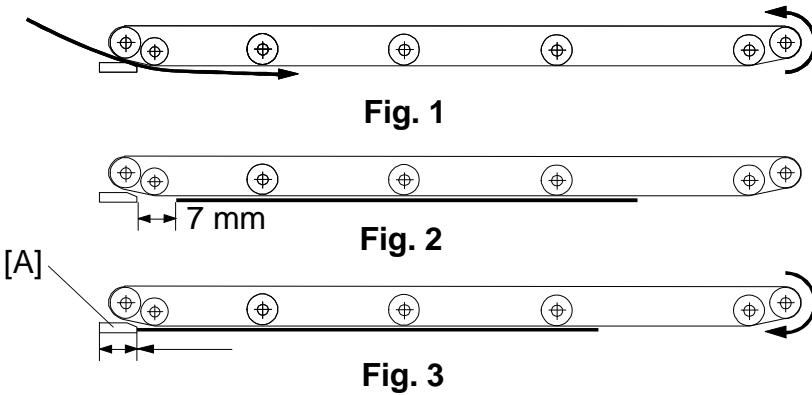

A548D521.wmf

This document feeder has two different ways of stopping originals at the correct position on the exposure glass. The technician can select one of these using a copier SP mode. The user can also select the mode.

### 1. Thick Original Mode (Normal Paper Mode)

This mode is the factory set mode. The belt drive motor remains energized to carry the original approximately 7 mm past the left scale (Figures 1 and 2). Then the motor pauses and reverses to feed the original back against the left scale (Fig. 3). This forces the original to hit against the left original scale [A] and thus aligns the trailing edge to minimize the original skew on the exposure glass.

### 2. Thin Original Mode

To protect originals from being damaged by the movements of the transfer belt, thin original mode can be selected. The belt drive motor stops shortly after the original trailing edge passes the registration sensor. This stops the original at the correct position on the exposure glass.

### 4.7 ORIGINAL FEED-OUT MECHANISM

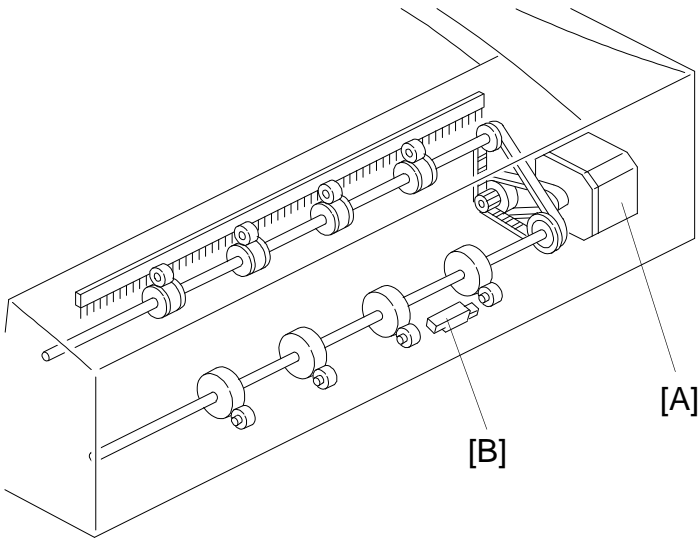

A548D522.wmf

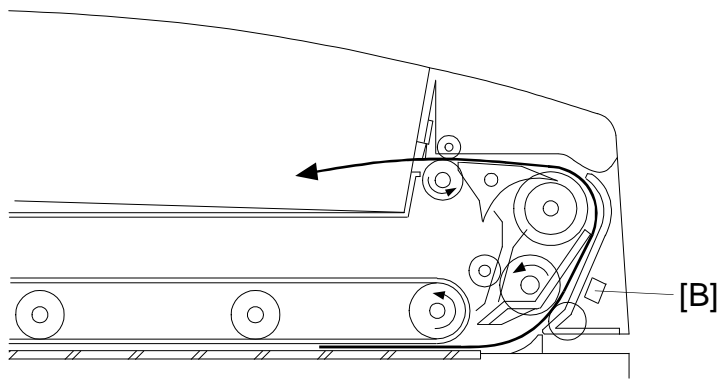

A548D523.wmf

When the scanner reaches the return position, the copier's CPU sends the feed-out signal to the DF CPU. When the DF receives the feed-out signal, the belt drive and feed-out motors [A] turn on.

The feed-out sensor [B] installed in the feed-out section counts the number of pulses to calculate how long the feed-out motor must stay on to feed the original out of the machine completely.

## 4.8 TWO-SIDED ORIGINAL FEED MECHANISM

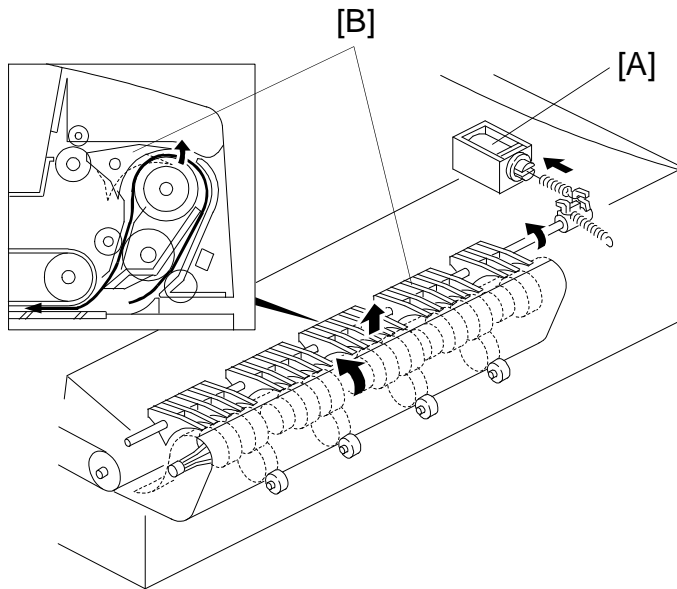

A548D524.wmf

Unlike one-sided original feed, the back side of the original must be copied first to keep the originals and copies in the correct order.

During original feed-in, the sequence is the same as for one-sided feed. However, the belt drive motor continues rotating until the original reaches the inverter section. The DF CPU also energizes the feed-out motor and the inverter solenoid [A] for a short time to lift the inverter pawls [B].

After the inverter mechanism inverts the original, the belt drive motor reverses and the original is fed towards the original scale. It is stopped at the correct position on the exposure glass, and the DF CPU sends the copy start signal.

When the scanner reaches the return position, the copier's CPU sends the invert original signal to the DF CPU in order to make a copy of the front side. The original is inverted in the same way as for copying the back side, as explained earlier on this page.

# 5. TIMING CHARTS

## 5.1 A4 SIDEWAYS: 1 SIDED ORIGINAL

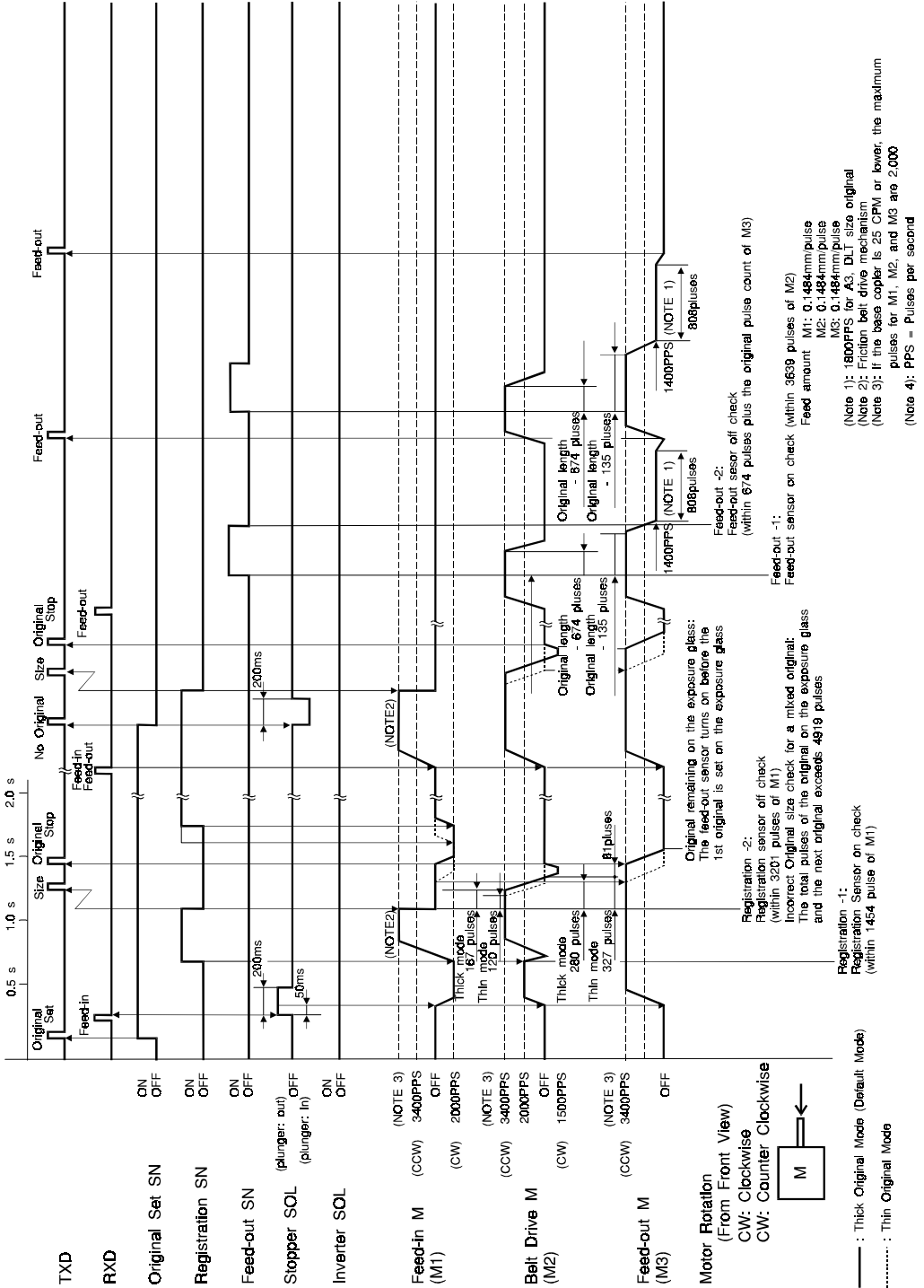

## 5.2 COMBINE 2 ORIGINAL MODE

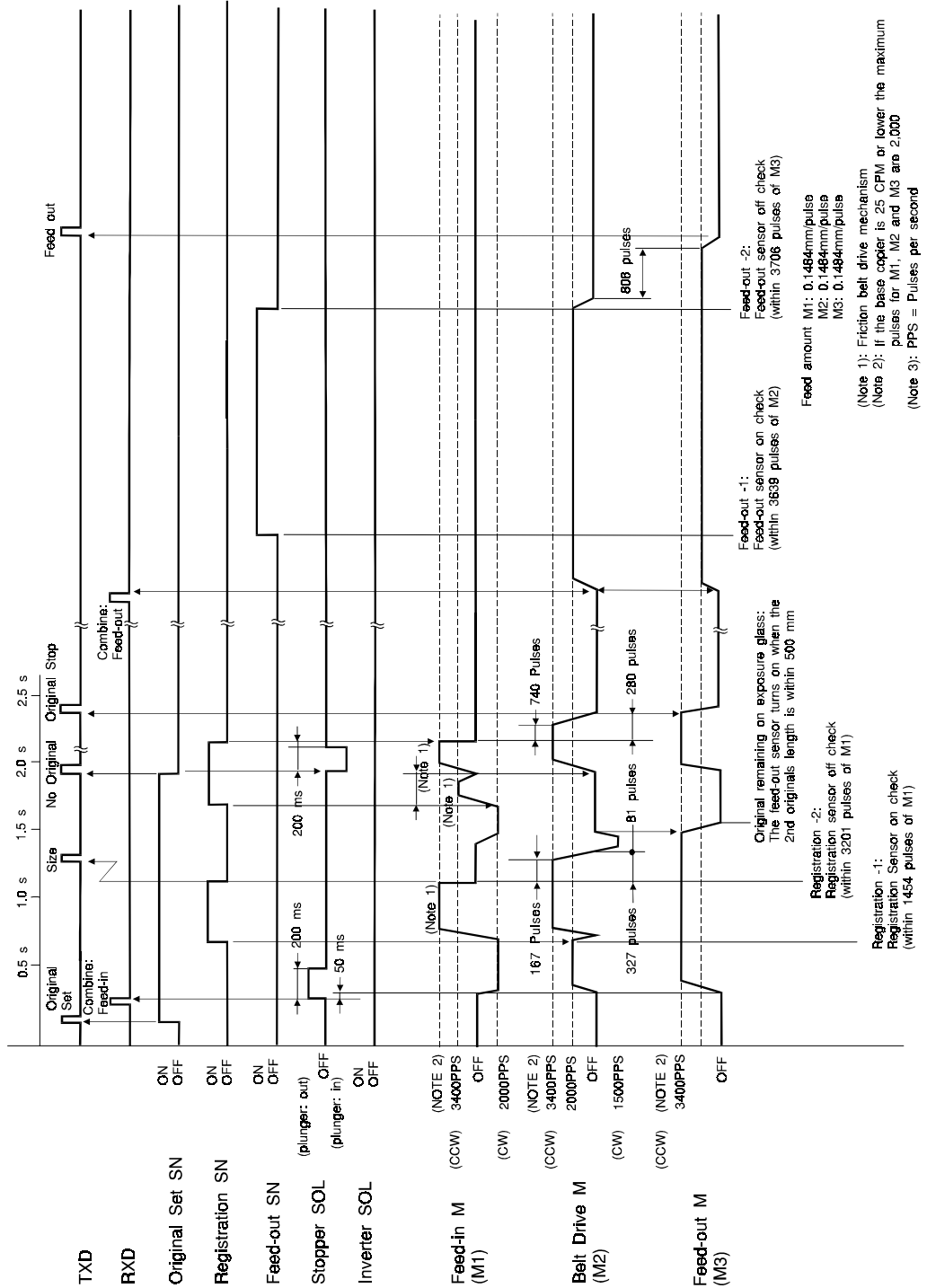

# 5.3 A4 SIDEWAYS: DUPLEX

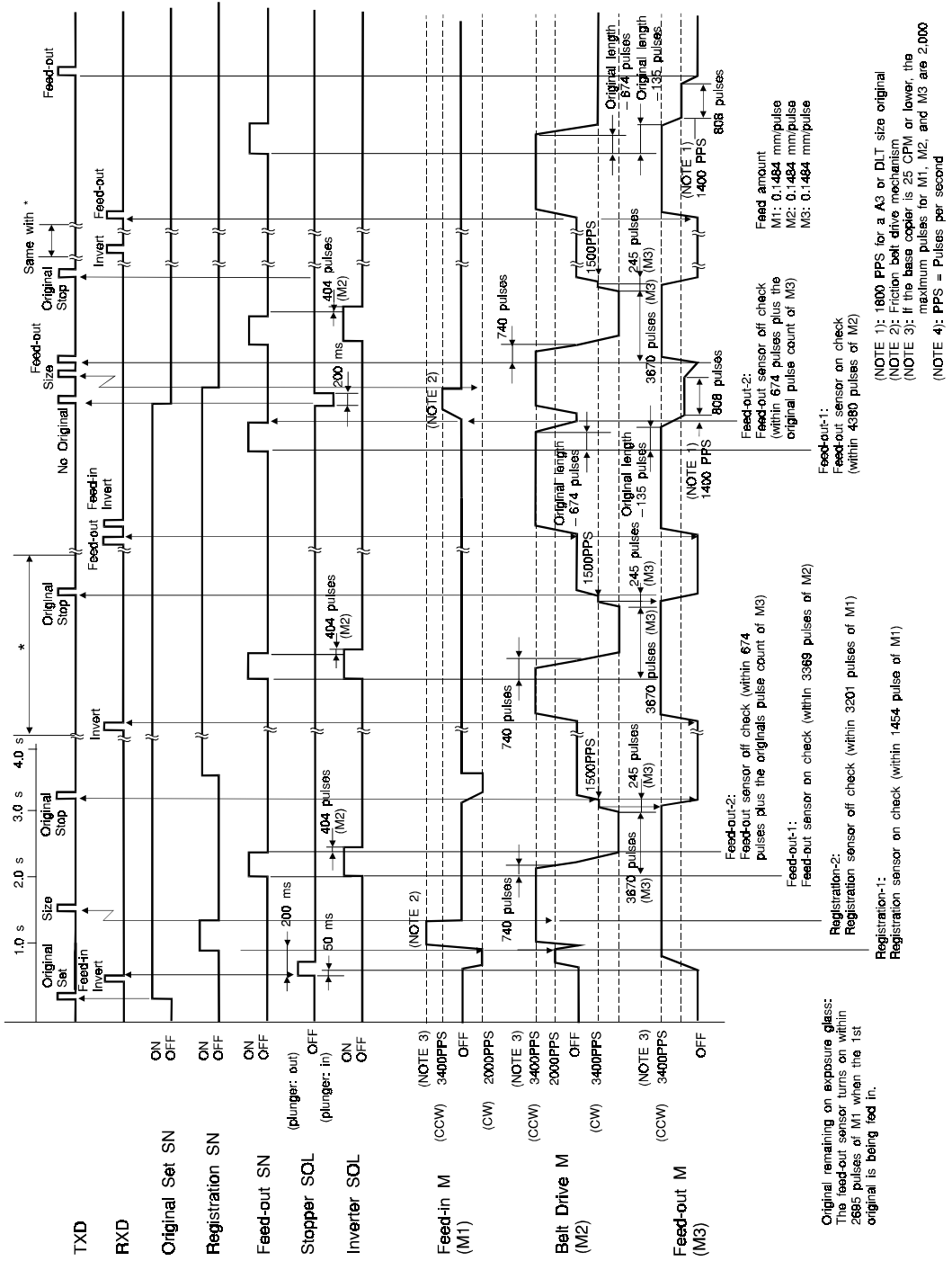

Original remaining on exposure glass:  
The feed-out sensor turns on within 2685 pulses of M1 when the 1st original is being fed in.





---

## **6. INSTALLATION**

### **6.1 ACCESSORY CHECK**

Check the quantity and condition of the accessories in the box against the following list:

1. New Equipment Condition Report ..... 1
2. Installation Procedure ..... 1
3. Stud Screw ..... 2
4. Philips Screw with Flat Washer – M4 x 10 ..... 2
5. Sponge Retainer ..... 1

## 6.2 INSTALLATION PROCEDURE

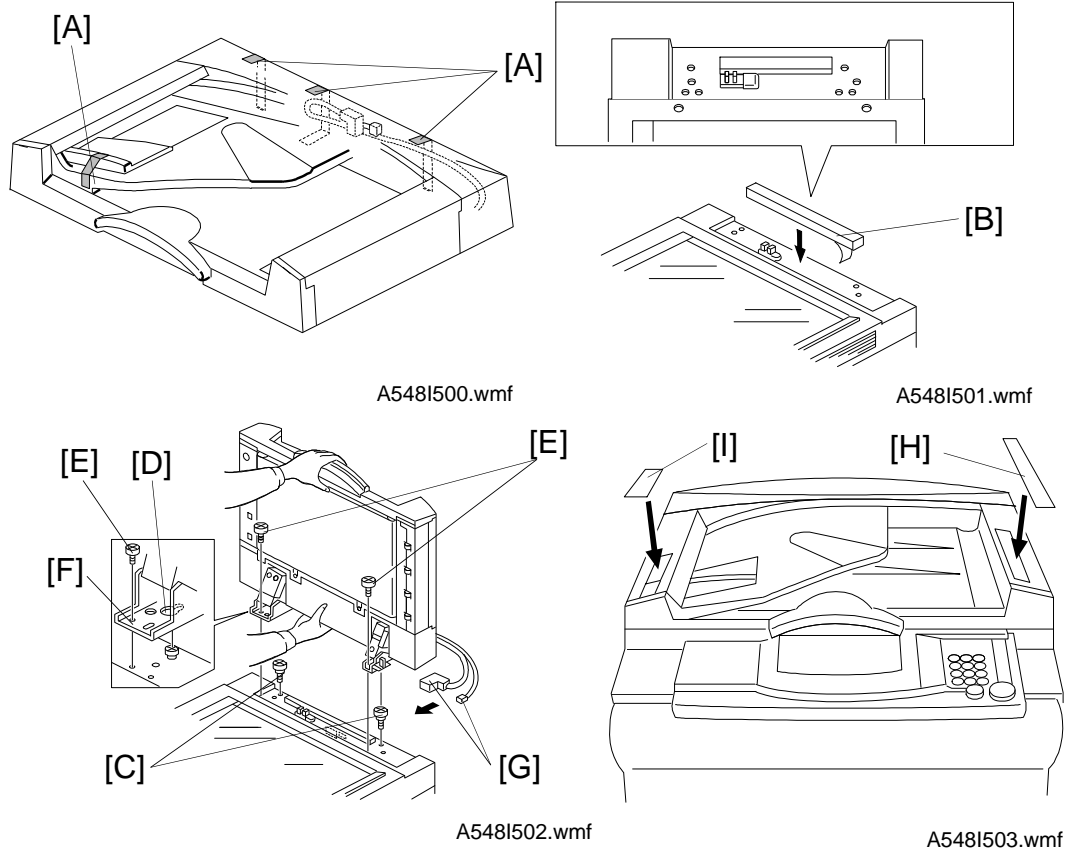

### **⚠ CAUTION**

**Unplug the copier power cord before starting the following procedure.**

1. Remove the strips of tape [A].
2. Attach the sponge retainer [B] to the top cover of the copier as shown.
3. Tighten the two stud screws [C].
4. Mount the ARDF by aligning the holes [D] in the ARDF and the stud screws [C], then slide the ARDF to the front as shown.
 

**NOTE:** When mounting the ARDF, hold it by hand as shown in the illustration. Holding it in another way may damage the ARDF.
5. Screw the two M4 x 10 screws [E] into the holes [F] and tighten them.
6. Connect the connectors [G] into the socket on the rear of the copier.
7. **All models except for the A156:** Attach the symbol explanation decal [H] and the combine originals explanation decal [I] to the ARDF as shown.

**Auto Reverse  
Document  
Feeder**

## 6. SERVICE TABLES

### 6.1 DIP SWITCHES

DPS 101				Function
1	2	3	4	
0	0	0	0	Normal setting
1	0	0	0	One-sided thin original mode free run with paper (35 cpm)
0	1	0	0	One-sided thick original mode (normal mode) free run with paper (35 cpm)
1	1	0	0	One-sided thick original mode (normal mode) free run without paper (35 cpm)
0	0	1	0	Two-sided mode free run with paper (35 cpm)
1	0	1	0	Two-sided mode free run without paper (35 cpm)
1	0	0	1	One-sided thin original mode free run with paper (25 cpm)
0	1	0	1	One-sided thick original mode (normal mode) free run with paper (25 cpm)
0	0	1	1	Two-sided mode free run with paper (25 cpm)
1	0	1	1	Not used
1	1	0	1	Solenoid test
0	1	1	0	Motor test
1	1	1	0	Combine two originals mode free run with paper
0	0	0	1	Not used
0	1	1	1	Not used
1	1	1	1	Indicators On

**NOTE:** a) Paper will automatically feed after 3 seconds when the "with paper" free run modes are selected.

b) To prevent the friction belt from wearing, open the feed-in cover when performing the "without paper" free run modes.

#### To make a free run

1. Set up dip switches 1 to 4 for the required free run mode the test begins automatically.
2. To stop the free run, put the dip switches back to 0.

## 6.2 VARIABLE RESISTORS

VR No.	Function
101	Adjusts the registration in one-sided thin original mode.
102	Adjusts the registration in two-sided original mode.

## 6.3 LED

LED No.	Function
101	Monitors the communication with the copier.

## 6.4 FUSE

FUSE No.	Function
101	Protects the 24 V line.

## 7. REPLACEMENT AND ADJUSTMENT

### 7.1 TRANSPORT BELT REPLACEMENT

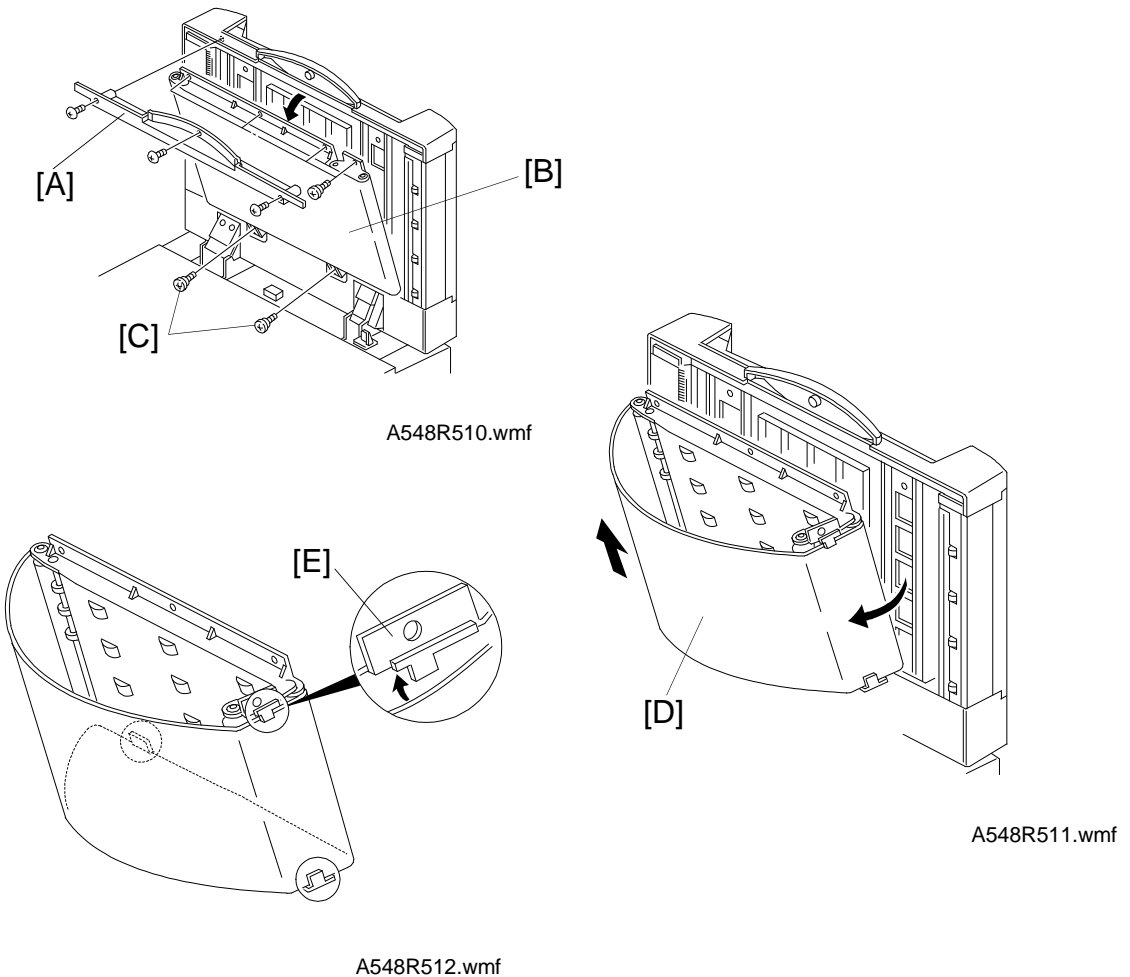

1. Turn off the main switch and lift up the DF.
2. Remove the grip [A] (3 screws).
3. Remove the 6 screws securing the transport belt assembly [B].  
**NOTE:** Remove the two lower screws [C] first.
4. Bend the transport belt assembly and pull out the transport belt [D] as shown.

- NOTE:** a) When installing the transport belt, make sure that the belt runs under the belt guide spacers [E].
- b) When securing the transport belt assembly with the 6 screws, make sure to secure the four upper screws first.

## 7.2 FEED ROLLER REPLACEMENT

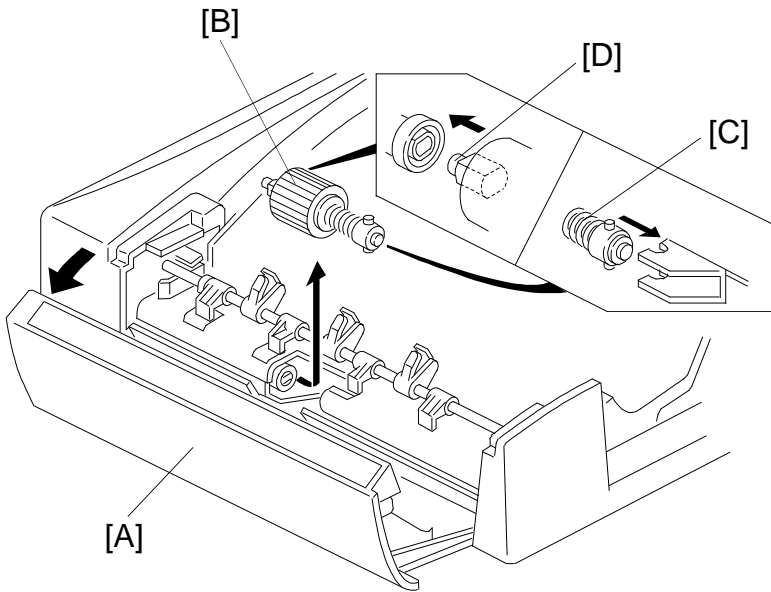

A548R513.wmf

1. Turn off the main switch and open the feed-in cover [A].
2. Remove the feed roller assembly [B] by pulling it towards the front.
3. Replace the feed roller.

**NOTE:** When installing the feed roller assembly, make sure the pins [C, D] on both sides are fixed properly.

### 7.3 FRICTION BELT REPLACEMENT

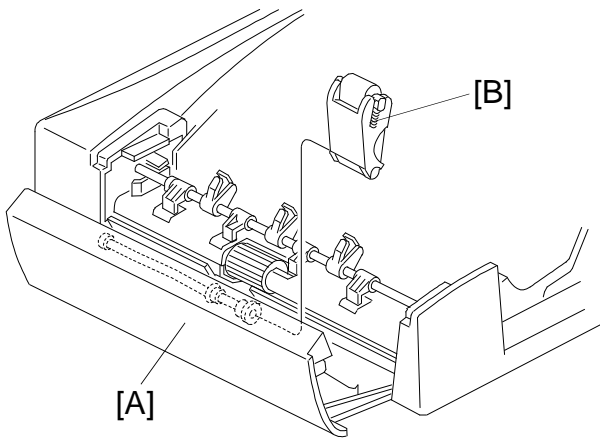

A548R514.wmf

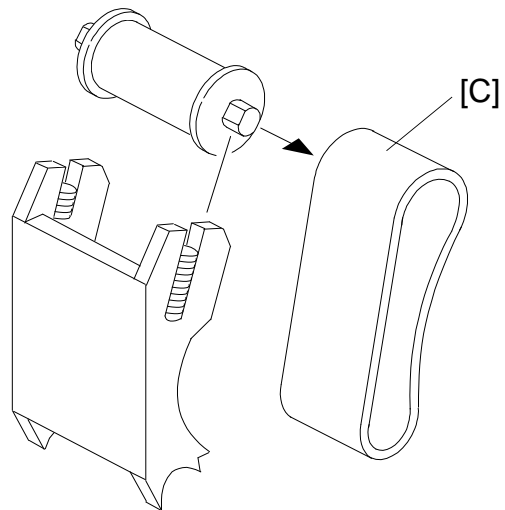

A548R515.wmf

1. Turn off the main switch and open the feed-in cover [A].
2. Gently pull up the friction belt assembly [B] and remove it from the shaft.
3. Replace the friction belt [C].

### 7.4 ORIGINAL SET AND ORIGINAL WIDTH SENSOR REPLACEMENT

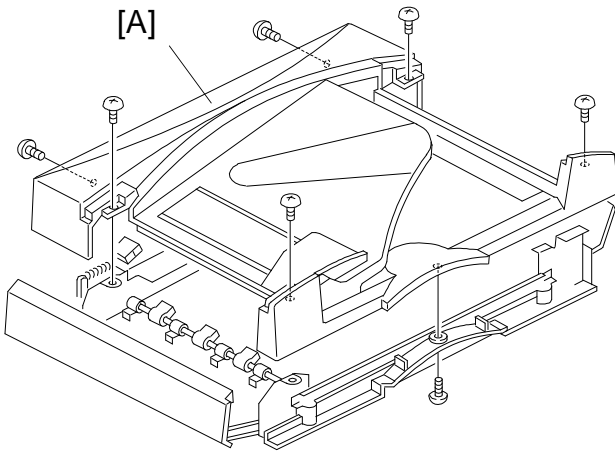

A548R516.wmf

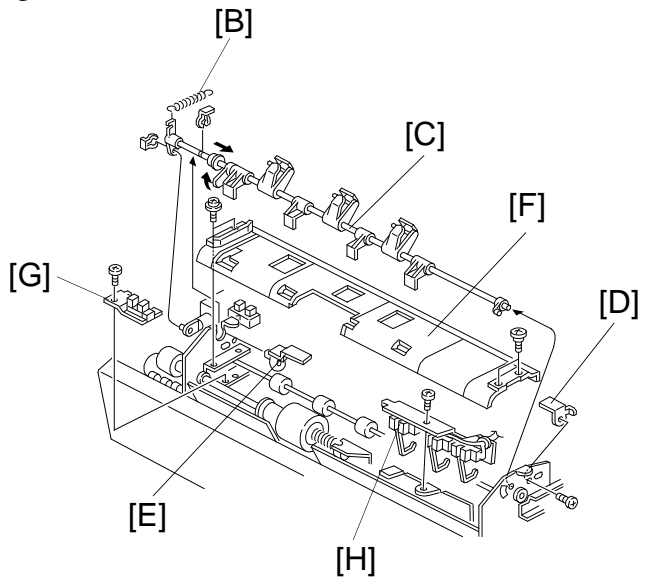

A548R517.wmf

1. Turn off the main switch.
2. Remove the upper cover [A] (7 screws).
3. Remove the pick-up solenoid spring [B].
4. Remove the stopper/pressure lever shaft [C] (2 E-rings).
5. Remove both front [D] and rear [E] feed-in cover magnet catches (1 screw each).
6. Remove the feed-in guide plate [F] (4 screws).
7. Remove the original set sensor assembly [G] (1 screw).
8. Remove the original width sensor assembly [H] (1 screw).
9. Replace the required sensor.



## 7.5 VERTICAL REGISTRATION ADJUSTMENT

### 7.5.1 One Sided Thin Original Mode

#### Note:

- After replacing the DF main board, always do the Rough Adjustment using VR101 first. Then do the Fine Adjustment procedure.
- At other times, just do the Fine Adjustment procedure.
- After finishing the adjustment, be sure to turn off the dip switch.

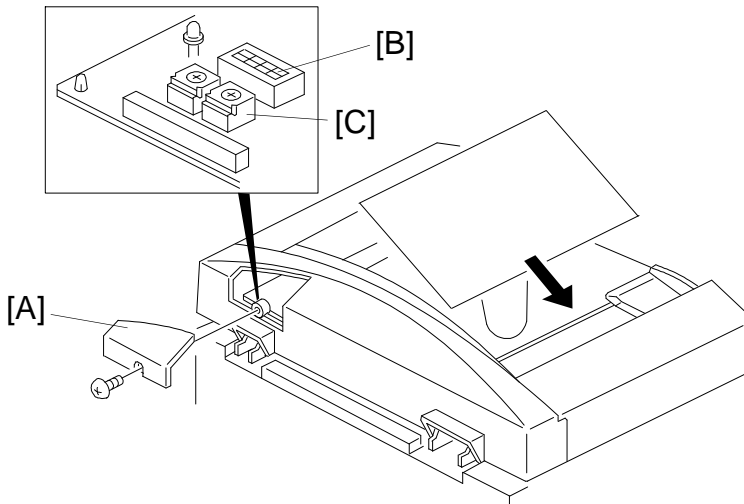

A548R518.wmf

#### - Rough Adjustment (Using VR101) -

1. Remove the small cover [A] at the rear of the DF upper cover (1 screw).
2. Turn on dip switch 101-1 [B].
3. Place a sheet of A4/81/2" x 11" sideways paper (64 g/m<sup>2</sup>, 17 lb) on the original table. (The paper will feed automatically.)
4. After the original stops on the exposure glass, raise the DF carefully so that the original does not move.
5. Check that the gap between the trailing edge of the paper and the left original scale is  $0 \pm 2.5$  mm.
6. If the gap is not within this specification, adjust the registration with VR101 [C]. (Turning VR101 counter-clockwise will increase the gap.)

#### - Fine Adjustment (Using a Copier SP Mode) -

1. Perform steps 1 through 5 of the rough adjustment procedure.
2. If the gap is larger than 2.5 mm, adjust the registration with the copier SP mode for the DF Registration Adjustment in one-sided original mode. (Increasing the setting will increase the gap.)

### 7.5.2 Two Sided Original Mode

**Note:**

- After replacing the DF main board, always do the Rough Adjustment using VR102 first. Then do the Fine Adjustment procedure.
- At other times, just do the Fine Adjustment procedure.
- After finishing the adjustment, be sure to turn off the dip switch.

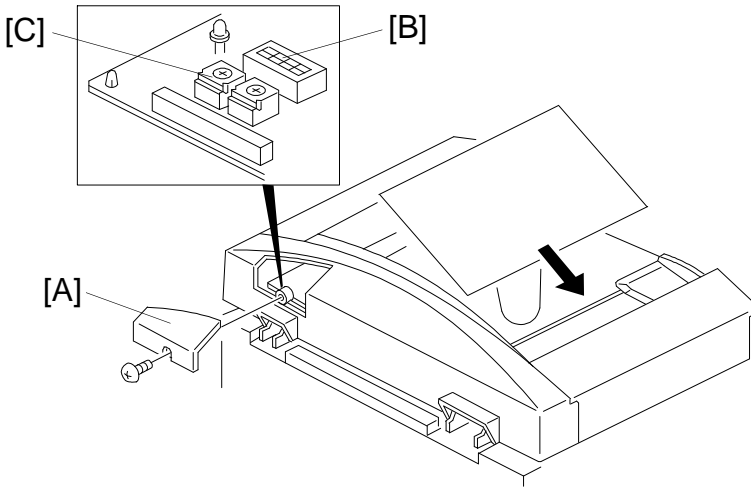

A548R518.wmf

#### - Rough Adjustment (Using VR102) -

1. Remove the copier's left original scale (2 screws).
2. Remove the small cover [A] at the rear of the DF upper cover (1 screw).
3. Turn on dip switch 101-3 [B].
4. Place a sheet of A4/81/2" x 11" sideways paper (64 g/m<sup>2</sup>, 17 lb) on the original table. (The paper will feed automatically.)
5. After the original stops on the exposure glass, raise the DF carefully so that the original does not move.
6. Check that the gap between the trailing edge of the paper and the left edge of the original rear scale is 10 ± 2 mm.
7. If the gap is not within this specification, adjust the registration with VR102 [C]. (Turning VR102 counter-clockwise will increase the gap.)

#### - Fine Adjustment (Using a Copier SP Mode) -

1. Perform steps 1 through 6 of the rough adjustment procedure.
2. If the gap is not within specification, adjust the registration with the copier SP mode for the DF Registration Adjustment in two-sided original mode. (Increasing the setting will increase the gap.)

## 7.6 SIDE-TO-SIDE REGISTRATION (DF POSITIONING) ADJUSTMENT

### Note:

- First, adjust the DF side-to-side registration using the copier SP mode for this (see Replacement and Adjustment - Side-to-side Registration Adjustment in the copier manual).
- Do the following adjustment only when the registration cannot be brought within the specification ( $0 \pm 2$  mm) using the above mentioned SP mode.

SPECIFICATION (Original position from the rear scale)

<b>Thick (Normal) Paper Original Mode</b>	$3.5 \pm 2$ mm ( $3.5 \pm 3$ mm for B6 lengthwise)
<b>Thin Original Mode</b>	$3.5 \pm 2$ mm
<b>Two Sided Original Mode</b>	$3.5 \pm 3$ mm

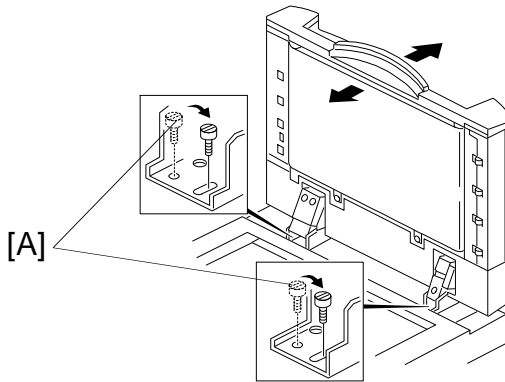

A548R519.wmf

1. Place a sheet of A4/81/2" x 11" sideways paper (64 g/m<sup>2</sup>, 17 lb) on the original table and press the Print key.
2. After the original stops on the exposure glass, raise the DF carefully so that the original does not move.
3. Check if the gap between the rear edge of the paper and the rear original scale is within the specification listed above.
4. If it is out of specification, reposition the 2 screws [A] securing the DF hinge to the long screw hole as shown.
5. Repeat steps 1 to 3.
6. Secure the DF unit at the position where the gap falls within specification.
7. Check the copy quality and adjust the ADF side-to-side registration with the copier SP mode if it is not within the  $0 \pm 2$  mm specification (see Replacement and Adjustment - Side-to-side Registration Adjustment in the copier manual).

# ARDF(A548) POINT TO POINT DIAGRAM

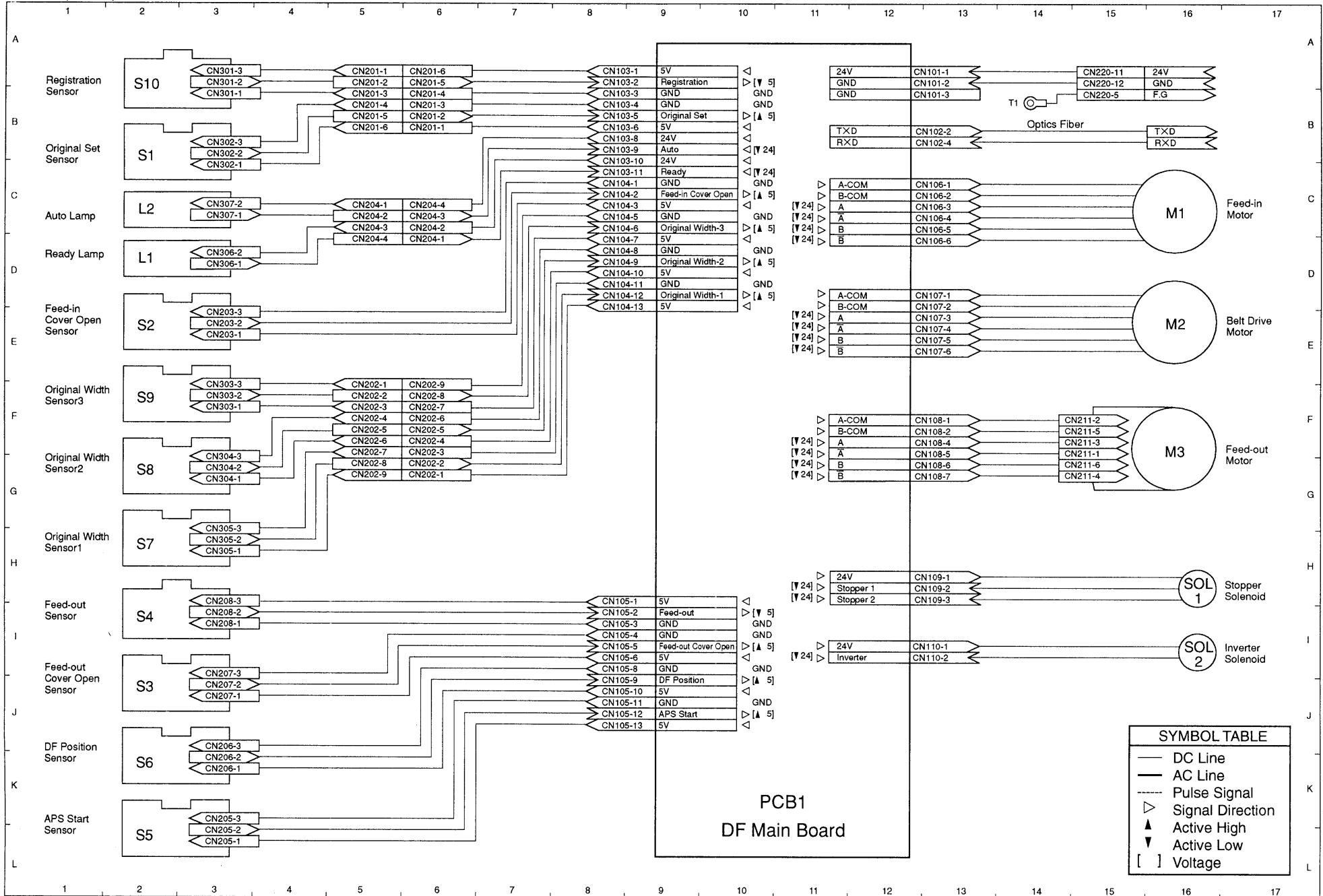

# ARDF (A548) ELECTRICAL COMPONENT LAYOUT

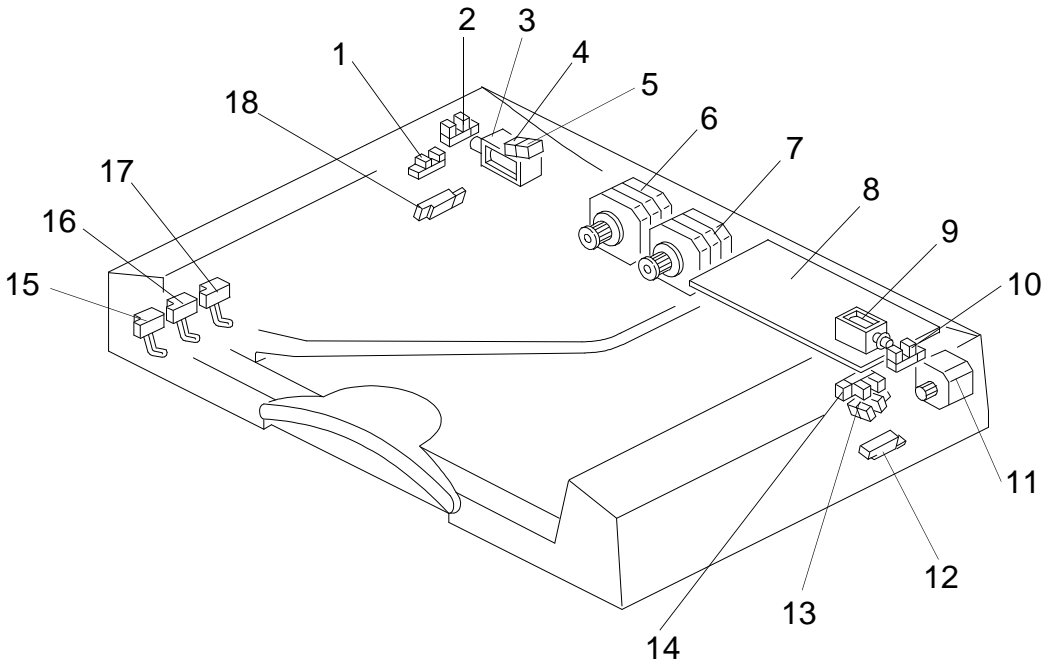

A166s505.wmf

Index No.	Description	P to P Location
1	Original Set Sensor (S1)	B3
2	Feed-in Cover Open Sensor (S2)	E3
3	Stopper Solenoid (SOL1)	I16
4	Ready Lamp (L1)	D3
5	Auto Lamp (L2)	C3
6	Feed-in Motor (M1)	C16
7	Belt Drive Motor (M2)	E16
8	DF Main Board (PCB1)	F11
9	Inverter Solenoid (SOL2)	J16
10	Feed-out Cover Open Sensor (S3)	J3
11	Feed-out Motor (M3)	F16
12	Feed-out Sensor (S4)	I3
13	APS Start Sensor (S5)	L3
14	DF Position Sensor (S6)	K3
15	Original Width Sensor-1 (S7)	H3
16	Original Width Sensor-2 (S8)	G3
17	Original Width Sensor-3 (S9)	F3
18	Registration Sensor (S10)	A3